

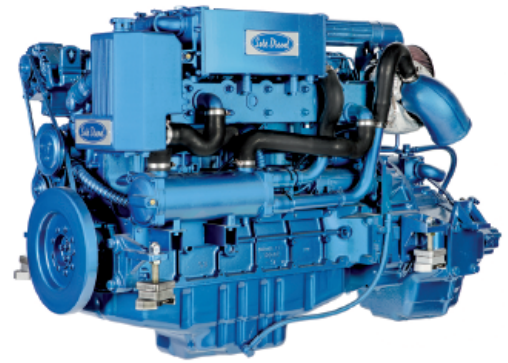

SDZ-280

Inboard Engine Base DEUTZ

6 cylinders · 272 HP (200 kW) at 2.300 rpm



Technical Specifications

Base	DEUTZ
Type	Diesel. 4 - Stroke Cycle
Number of Cylinders	6 in line
Intake System	Turbocharger and intercooler
Bore and Stroke	108 x 130 mm
Total Displacement	7.150 cc
Compression Ratio	17.5:1
Intermittent Power (ISO 3046/1)	272 HP (200 kW)
Continuous Power	238,5 HP (175,5 kW)
Rated RPM	2.300
Combustion System	Direct
Starter motor	24 V (4 kW)
Alternator	55 A
Engine. Max. Install. Angle	10 continuous.
Direction of Rotation (Crankshaft)	Anti Clockwise (View from Stern)
Cooling System	Heat Exchanger Cooled
Dry Weight	657 Kg
Water Hose (Inside Diameter)	38 mm
Fuel Feed Hose (Inside Diameter)	12 mm
Fuel Return Hose (Inside Diameter)	12 mm
Exhaust hose (inside Diameter)	125 mm
Certifications	EU RCD / EIAPP Tier II (IMO)

Gearbox

Model	TM265	TM265A	TM360	TM1200A
Type	Hydraulic	Hydraulic	Hydraulic	Hydraulic
Down Angle	-	7°	-	7°
Reduction Ratio (Pleasure)	2,09:1 - 2,82:1	2,00:1 - 2,30:1	3,00:1 - 3,50:1 - 4,00:1 - 5,00:1	1,44:1 - 2,00:1
Reduction Ratio (Cont. Duty)	2,09:1 - 2,82:1	-	3,00:1 - 3,50:1 - 4,00:1 - 5,00:1	1,44:1 - 2,00:1
Engine Weight with Gearbox	841 Kg	841 Kg	1.091 Kg	791 Kg



www.solediesel.com

Detailed drawings, brochures and manuals are available on the web. © 2013, Solé Diesel. All rights reserved. Technical specifications, data and presentation are subjected to variations, changes and updates without prior notice, and without any obligation or liability whatsoever. Text and illustrations are not binding.

Performance Curves

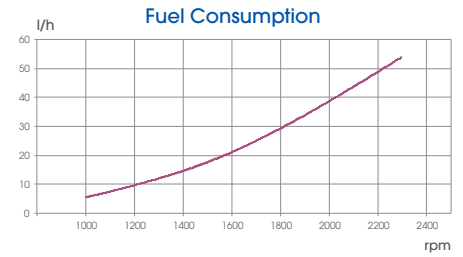
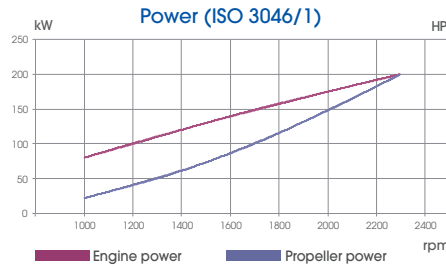
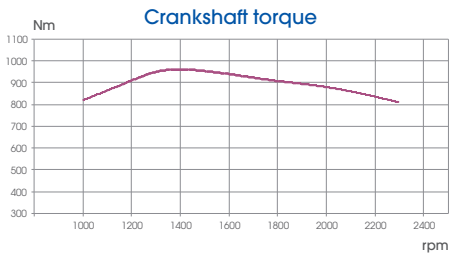

Instrument panel



Deluxe - TE3

- Tachometer
- Hour Meter
- Battery Warning Light
- Temperature Gauge
- Audible and visual alarm for low oil pressure and high engine temperature
- Voltmeter
- Oil Pressure Gauge
- Dimensions: 150 x 250 mm



Double panel - TE4

- Tachometer
- Hour Meter
- Battery Warning Light
- Audible and visual alarm for low oil pressure and high engine temperature
- Key start / Stop
- Dimensions: 180 x 150 mm

Accessories

Standard Equipment

- Packaging
- Instrument Panel TE3
- 4m extension harnessge
- Diesel prefilter
- Diesel manual pump
- Sump drain pump
- Owners manual

Optional Equipment

- We have a wide range of available accessories and kits.
- Our technical department will calculate the propeller to optimize your engine.
- For additional information access our website.

Dimensions

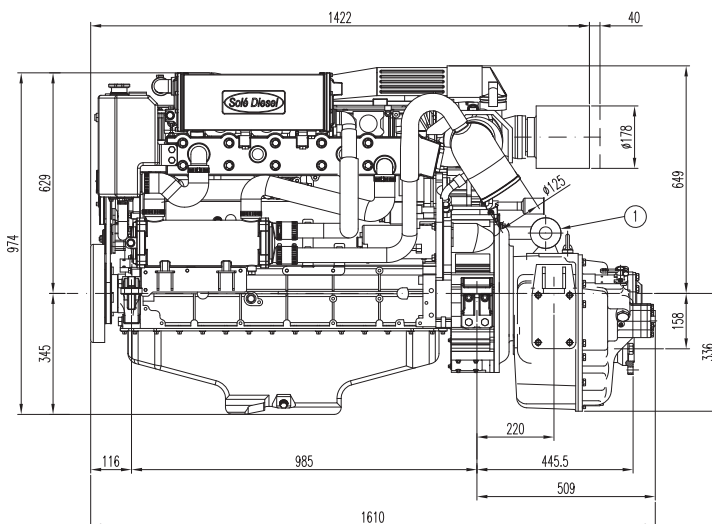

SDZ-280 with TM-265

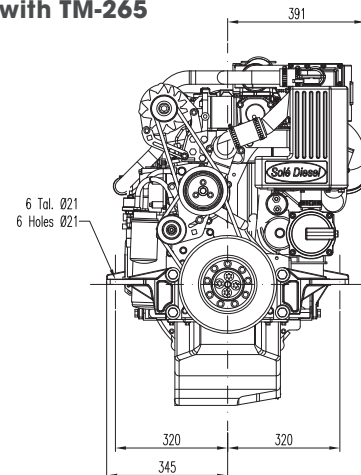

Dimensions in mm

Authorized Dealer

Sole Diesel SOLÉ, S.A. C-243 b, km 2. 08760 Martorell. Barcelona.

Office tel. +34 93 775 14 00 - Fax +34 93 775 30 13

www.solediesel.com - info@solediesel.com



Detailed drawings, brochures and manuals are available on the web. © 2013. Solé Diesel. All rights reserved. Technical specifications, data and presentation are subjected to variations, changes and updates without prior notice. Text and illustrations are not binding.